

JVC

SERVICE MANUAL

COMPACT VHS CAMCORDER

GR-FXM17A/FXM170A

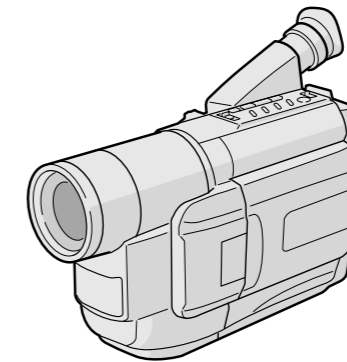

Compact VHS



Regarding service information other than these sections, refer to the GR-FXM37EG service manual (No. 86589). Also, be sure to note important safety precautions provided in the service manual.

SPECIFICATIONS *(The specifications shown pertain specifically to the model GR-FXM17A/170A)*

Camcorder

General

Format	: VHS PAL standard
Power source	: DC 11 V --- (Using AC Adapter) DC 6 V --- (Using battery pack)
Power consumption	
Viewfinder on	: 4.0 W
LCD monitor on	: 4.5 W
Signal system	: PAL-type
Video recording system	
Luminance	: FM recording
Colour	: Converted sub-carrier direct recording Conforms to VHS standard
Cassette	: S VHS / V VHS cassette
Tape speed	
SP	: 23.39 mm/sec.
LP	: 11.70 mm/sec.
Recording time (max.)	
SP	: 60 minutes
LP	: 120 minutes (with EC-60 cassette)
Operating temperature	: 0°C to 40°C

Operating humidity	: 35% to 80%
Storage temperature	: -20°C to 50°C
Weight	: Approx. 900 g
Dimensions (W x H x D)	: 200 mm x 112 mm x 118 mm
Pickup	: 1/4" format CCD
Lens	: F1.6, f = 3.9 mm to 62.4 mm, 16:1 power zoom lens with auto iris and macro control, filter diameter 40.5 mm
Viewfinder	: Electronic viewfinder with 0.5" black/white CRT
White balance adjustment	: Auto/Manual adjustment
LCD monitor	: 2.5" diagonally measured, LCD panel/TFT active matrix system
Speaker	: Monaural
Connectors	
JLIP/EDIT	: ϕ 3.5 mm, 4-pole, mini-head jack (compatible with RC-5325 plug)
Video	: 1 V (p-p), 75 Ω unbalanced, analogue output (via Video output connector)
Audio	: 300 mV (rms), 1 k Ω analogue output (via Audio output connector)

AC Adapter AP-V10A

Power requirement	: AC 110 V to 240 V \sim , 50 Hz/60 Hz
Output	: DC 11 V --- , 1 A
Dimensions (W x H x D)	: 59 mm x 31 mm x 84 mm
Weight	: Approx. 140 g (not including Power Cord)

Optional Accessories

- Battery Packs BN-V12U, BN-V20U, BN-V400U
- Compact S-VHS (**S**VHS) Cassettes SE-C45/30
- Compact VHS (**V**VHS) Cassettes EC-60/45/30
- Remote Control Unit RM-V700U
- Active Carrying Bag CB-V7U
- Cassette Adapter C-P7U

Some accessories are not available in some areas. Please consult your nearest JVC dealer for details on accessories and their availability.

Specifications shown are for SP mode unless otherwise indicated. E & O.E. Design and specifications subject to change without notice.

JVC

VICTOR COMPANY OF JAPAN, LIMITED
VIDEO DIVISION

S40894

TABLE OF CONTENTS

DIFFERENT TABLE 1 to 2

5. PARTS LIST

5.1 PACKING AND ACCESSORY ASSEMBLY <M1> 5-1
 5.2 FINAL ASSEMBLY <M2> 5-3

The following table indicate main different points between models GR-FXM37EG,GR-FXM17A and GR-FXM170A.

ITEM \ MODEL	GR-FXM37EG	GR-FXM17A	GR-FXM170A
AC ADAPTER	AP-V10EG	AP-V10A	AP-V10A
BODY/UPPER CASE COLOR	Silver/Silver	Black/Black	Black/Silver
CASSETTE ADAPTER	Optional	Optional	Provided
CONNECTOR,CABLE ADAPTER	Provided	Optional	Optional
CONVERSION PLUG	Optional	Provided	Provided
ZOOM	400X	600X	600X

The following table indicate different parts number between models GR-FXM37EG,GR-FXM17A and GR-FXM170A.

PACKING AND ACCESSORY ASSEMBLY <M1> Note: As for IB (INSTRUCTIONS), refer to sec.5.

REF. NO. \ MODEL	GR-FXM37EG	GR-FXM17A	GR-FXM170A
1	LY32179-002A	LY32054-095A	LY32054-075A
7	BT-54013-1	—	—
△ 10	LY20688-001A	LY20688-003A	←
13	—	LYT0609-001A	←
19	PEMC1174	—	—
△ 20	—	PEMC1012-02	←
21	—	—	YQ31963A-3 or YQ31963B-3
22	Not used	Not used	Used

FINAL ASSEMBLY <M2>

REF. NO. \ MODEL	GR-FXM37EG	GR-FXM17A	GR-FXM170A
101F	* QYSLSF2060D	QYSLSF2050Z	←
104	LY20683-013A	LY20683-006B	←
104E	LY30934-020A	LY30934-017A	←
105	LY20694-002A	LY20694-001A	←
106	LY10257-005B	LY10257-024A	LY10257-020B
109	LY20614-014B	LY20614-004B	←
121	* QYSLSF2060D	QYSLSF2050Z	←
136	* QYSLSF2060D	LY42981-001A	←

Note: Mark — is not used. Mark ← is same as left. Mark * reference model was also changed.

MONITOR ASSEMBLY <M5>

REF. NO.	MODEL		GR-FXM37EG	GR-FXM17A/170A
	ITEM			
△ 500	MONITOR ASSY		LYH20217-017A	LYH20217-006A
△ 501	M. COVER ASSY		LY20679-005A	LY20679-004A
504	HINGE COVER(U)		LY31939-001A	LY31939-003A

MAIN BOARD ASSEMBLY <01>

REF. NO.	MODEL		GR-FXM37EG	GR-FXM17A/170A
	ITEM			
PW	MAIN BOARD ASSY		YB10310EH-01	YB10310ES-01
R4704	CMF RESISTOR		* NRVA63D-271X	NRVA63D-272X
R4705	CMF RESISTOR		* NRVA63D-471X	NRVA63D-472X
R4722	CMF RESISTOR		* NRVA63D-680X	NAVA63D-750X
R4748	CMF RESISTOR		* -	NRVA63D-333X
R6616	MG RESISTOR		* NRSA63J-392X	NRSA63J-102X
R7049 to R7051	MG RESISTOR		* NRSA63J-470X	NRSA63J-680X
C6305	CAPACITOR		* NDC31HJ-221X	NCB31HK-561X
C7019	CAPACITOR		* NDC31HJ-270X	NDC31HJ-121X
C7020	CAPACITOR		* NDC31HJ-270X	NDC31HJ-151X

Note: Mark - is not used. Mark * reference model was also changed.